

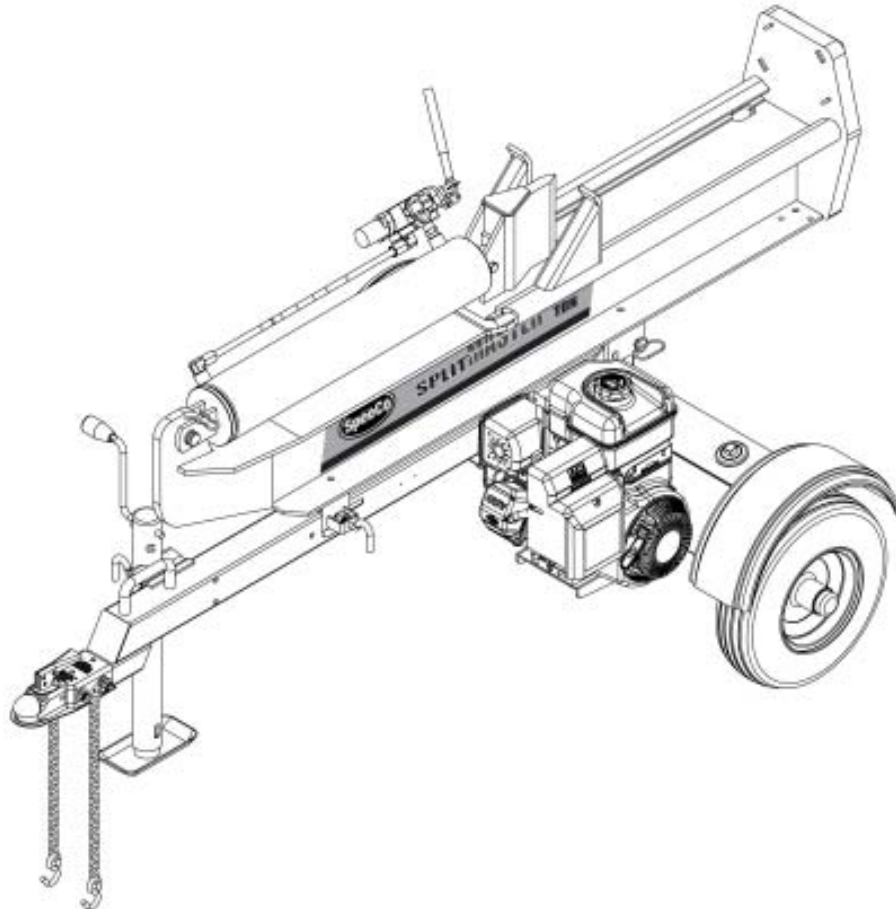

# 35 TON VERTICAL/HORIZONTAL LOG SPLITTER

**SPLITMASTER**



**MODEL NO.**

**401635PH**

## **Owner's Manual**

### **ASSEMBLY & OPERATING INSTRUCTIONS**



*This safety alert symbol identifies important safety messages in this manual. Failure to follow this important safety information may result in serious injury or death.*

# Table of Contents

	Page(s)
Important Safety Information.....	1-6
Intended Use .....	1
Personal Protective Equipment .....	1
Safety Decals .....	1-2
General Safety .....	3
Preparation of the Log .....	3
Work Area .....	3
Operation of the Log Splitter .....	3-4
Repair and Maintenance Safety .....	4
Hydraulic Safety .....	5
Fire Prevention .....	5-6
Towing Safety .....	6
Assembly Instructions .....	7-10
Operating Instructions .....	13-14
Engine Oil Recommendations .....	13
Hydraulic Oil Recommendations .....	13
Starting Instructions .....	13
Operation .....	14
Towing .....	14
Maintenance .....	15
Parts Breakdown Illustrations.....	10-12
Warranty Information .....	16
Specifications .....	Back Cover



# IMPORTANT SAFETY INFORMATION



**WARNING:** Read and thoroughly understand all instructions and safety information before assembling or operating this log splitter. Failure to do so may cause serious injury or death. Do not allow anyone to operate this log splitter who has not read this manual. As with all power equipment, a log splitter can be dangerous if assembled or used improperly. Do not operate this log splitter if you have doubts or questions concerning safe operation. Call our customer service department at 1-800-525-8322 to address these concerns.

*Si no entiende ingles, se prefiere que busque alguien que interprete las instrucciones para usted.*

## INTENDED USE

**NEVER** use this log splitter for any other purposes than splitting wood. It is designed for this use **only**. Any other use can cause serious injury or death.

## PERSONAL PROTECTIVE EQUIPMENT



**BEFORE** operating this log splitter make sure that you wear safety gear such as goggles or safety glasses, steel toed shoes and tight fitting gloves (without loose cuffs or draw strings). Always wear a protective hearing device when operating this log splitter.

**NEVER** wear loose clothing or jewelry that can be caught by moving parts of the log splitter. Keep clothing and hair away from all moving parts when operating this log splitter.

## SAFETY DECALS

Make sure that all safety warning decals are in good condition and readable. Always replace missing or defaced decals. Contact Special Products Co. at 1-800-525-8322 for replacement decals.

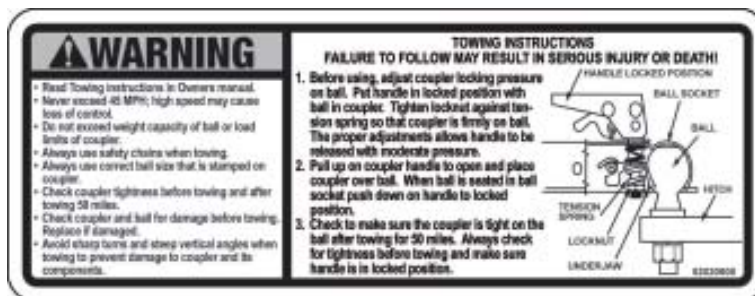

PART NUMBER: 52020000  
LOCATION: TOP, FRONT END OF TONGUE



# IMPORTANT SAFETY INFORMATION

**OPERATOR SAFETY**

**WARNING**



- Read and understand owner's manual thoroughly before operation. Failure to do so may result in serious injury. Manual also available online.
- Only one person should load and operate the log splitter. Keep all others away during operation. Never allow one person to operate the valve while another is positioning the log.
- Always position the log with hands on the sides of the log. Keep hands clear of ends.
- Do not operate log splitter under the influence of alcohol, drugs, or medication.
- Never check for leaks with your hands. High pressure fluid can escape through small holes and cause serious injury which could result in blood poisoning.
- Always stay in the operator zone when operating the log splitter.
- Keep hands, feet and clothing away from power driven parts.
- Do not attempt to step or reach over log splitter.
- Do not add gasoline while the engine is hot or running. Allow all spilled gas to evaporate before using log splitter.
- Always operate outdoors. Exhaust gases contain carbon monoxide. This odorless gas can be deadly when inhaled.

**CAUTION**

- Always wear safety glasses, safety shoes, and protective hearing devices during operation.
- Always shut off engine when leaving log splitter unattended, even for a short time.
- Always operate log splitter on level, dry, non-slippery surfaces. Keep off slopes.
- Keep work area clear of split wood, debris and other obstacles.
- Always split wood in the direction of the grain.

**OPERATING INSTRUCTIONS**

1. Read the Owner's manual for complete safety and operation instructions. Manual also available online.
2. Set up the log splitter in a clear, level area. Make sure that the suction port of the tank is always on the lower side of the log splitter.
3. Block the wheels. Lock the log splitter into either horizontal or vertical position.
4. Start the engine, refer to the Owner's manual and the Engine Operating and Maintenance manual.
5. Place a log on the beam against the foot plate. Position the log with hands on the sides. Make sure the log is securely placed against the foot plate and the beam.
6. Depress the valve handle so that the cylinder will drive the wedge into the log.
7. Extend the cylinder until the log splits or to the end of the stroke. If the log has not completely split after the cylinder has reached the end of its extension, retract the cylinder.

Control Valve  
Retract ▲  
●  
Extend ▼

**For Responsive Service**  
Call 1-800-525-8322

7/01/2006

PART NUMBER: 51018900  
LOCATION: TOP OF HYDRAULIC CYLINDER

**DANGER**



**PINCH POINT**  
Keep Hands  
Clear

PART NUMBER: 52055200  
LOCATION: BOTH STRIPPER  
PLATES AND CYLINDER

**NOTICE**

KEEP TANK FILLED TO "OK" RANGE ON  
DIPSTICK. DO NOT FILL BEYOND "OK"  
RANGE. USE UNIVERSAL HYDRAULIC OIL  
OR DEXTRON II TRANSMISSION FLUID.



PART NUMBER: 52023200  
LOCATION: HYDRAULIC TANK  
LOWER TANK, RIGHT CORNER



# IMPORTANT SAFETY INFORMATION

## GENERAL SAFETY

**Failure to follow these instructions may result in serious injury or death.**

**ALWAYS** read the operator's manual before operation. It is located in the plastic canister on the tongue.

**NEVER** allow children to operate this log splitter. **NEVER** allow adults lacking proper instructions and understanding to operate this log splitter.

**KEEP** all people and pets a minimum of 10 feet away from your work area when operating this log splitter. Only the operator is to be near the log splitter during use.

**NEVER** actuate the control until all people are clear of the work area.

**NEVER** operate the log splitter when under the influence of alcohol, drugs or medication.

**NEVER** allow a person who is tired or otherwise not alert to operate the log splitter.

## PREPARATION OF THE LOG

Both ends of the log should be cut as square as possible to help prevent the log from riding out of the splitter during operation. Do not split logs greater than 26 in. in length.

## WORK AREA

**NEVER** operate the log splitter on slippery, wet, muddy or icy ground.

**ONLY** operate your log splitter on level ground. Operating on a slope could cause the log splitter to roll over or logs to fall off.

**NEVER** operate your log splitter in an enclosed area. Exhaust fumes contain carbon monoxide which can be deadly when inhaled.

**NEVER** attempt to move your log splitter over hilly or uneven terrain without a tow vehicle or adequate help.

**ALWAYS** block the wheels to prevent movement of the log splitter while in operation.

**ONLY** operate your log splitter in daylight or under good artificial light.

**ALWAYS** keep the work area clean. Remove split wood around your log splitter immediately so that you don't stumble over it.

## OPERATION OF THE LOG SPLITTER

**ONLY** operate the log splitter from the operator zone as shown in the diagram. The operator has the safest and most efficient access to the control valve and the beam in this location. Failure to operate the log splitter in this position can result in serious injury or death.

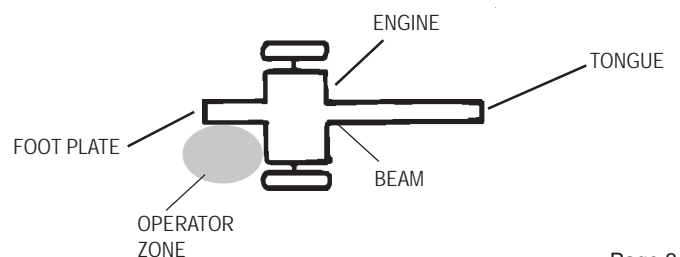



# IMPORTANT SAFETY INFORMATION

**KNOW** how to stop the log splitter and disengage the controls before operating it.

**NEVER** place hands or feet between the log and splitting wedge during forward or reverse stroke. Serious injury or death could result.

**NEVER** straddle or step over the log splitter during operation.

**NEVER** reach or bend over the log splitter to pick up a log.

**NEVER** try to split two logs on top of each other.

**NEVER** try to cross split a log.

**NEVER** attempt to load your log splitter when the ram or wedge is in motion.

**ALWAYS** use your hand to operate the control lever on the valve. **NEVER** use your foot, a rope or any extension device.

**NEVER** move the log splitter while the engine is running. Shut off the engine even if you are leaving the log splitter for a short period of time.

**ALWAYS** avoid contact with the muffler and other hot areas of the engine during operation or after running to prevent burns.

## REPAIR AND MAINTENANCE SAFETY

**NEVER** operate your log splitter when it is in poor mechanical condition or in need of repair.

Periodically check that all nuts, bolts, screws, hydraulic fittings and hose clamps are tight.

**NEVER** alter your log splitter in any manner. Such alterations may cause your log splitter to be unsafe and will void the warranty.

Perform all recommended maintenance procedures before using your log splitter.

Replace all damaged or worn parts immediately.

**NEVER** tamper with the engine to run it at excessive speeds. The maximum engine speed is preset by the manufacturer and is within safety limits. See Honda engine manual.

**ALWAYS** remove the spark plug wire before performing any service or repair on your log splitter.

**ALWAYS** check the level of hydraulic oil and engine oil before operation.

**ALL** replacement parts must meet manufacturer's specifications.



# IMPORTANT SAFETY INFORMATION

## HYDRAULIC SAFETY

The hydraulic system of your log splitter requires careful inspection along with the mechanical parts. Be sure to replace frayed, kinked, cracked or otherwise damaged hydraulic hoses or hydraulic components.

**NEVER** check for leaks of hydraulic fluid with your hand. Fluid escaping from a small hole can be almost invisible. Escaping fluid under pressure can have sufficient force to penetrate skin causing serious personal injury or even death. Leaks can be detected by passing a piece of cardboard over the suspected leak and looking for discoloration.

**ALWAYS** seek professional medical attention immediately if injured by escaping hydraulic fluid. Serious infection or reaction can develop if proper medical treatment is not administered immediately.

**ALWAYS** be sure to relieve all pressure by shutting off the engine and moving the valve control handle back and forth should it become necessary to loosen or remove any hydraulic fitting.

**NEVER** remove the cap from the hydraulic tank or reservoir while the log splitter is running. The tank could contain hot oil under pressure which could result in serious injury.

**NEVER** adjust the hydraulic valve. The pressure relief valve on your log splitter is preset at the factory. Only a qualified service technician should perform this adjustment.

## FIRE PREVENTION

**NEVER** operate your log splitter near a flame or spark. Hydraulic oil and gasoline are flammable and can explode.

**NEVER** fill the gas tank while the engine is hot or running. Allow the engine to cool before refueling.

**NEVER** smoke while operating or refueling your log splitter. Gas fumes can easily explode.

**ONLY** refuel your log splitter in a clear area with no gas fumes or spilled gas.

**ALWAYS** use an approved fuel container.

**ALWAYS** replace the gas cap securely.

If gasoline has spilled, move the log splitter away from the area of the spill and avoid creating any source of ignition until the spilled gas has evaporated.

**ALWAYS** take a Class B fire extinguisher with you when operating this log splitter in dry areas as a precautionary measure against possible flying sparks.

**ALWAYS** drain the fuel tank prior to storage to avoid the potential fire hazard.

**ALWAYS** store gasoline in an approved, tightly sealed container. Store the container in a cool, dry place.

**NEVER** store gasoline in the house or near a heating appliance.

**ALWAYS** turn the fuel shut off valve on the engine to the "OFF" position before towing the log splitter. Failure to do so may result in flooding the engine.



# IMPORTANT SAFETY INFORMATION

## **IMPORTANT NOTE:**

This log splitter is equipped with an internal combustion engine and should not be used on or near any unimproved forest-covered, brush-covered or grass-covered land unless the engine's exhaust system is equipped with a spark arrester meeting applicable local or state laws (if any). If a spark arrester is used, it should be maintained in effective working order by the operator. In the state of California a spark arrester is required by law. Other states have similar laws. Federal laws apply on federal lands. A spark arrester muffler (optional by manufacturer) is available as an accessory at your nearest engine dealer. Always check the legal requirements in your area.

## **TOWING SAFETY**

**ALWAYS** check all local and state regulations regarding towing, licensing, and lights before towing your log splitter.

**ALWAYS** check before towing to make sure that the log splitter is correctly and securely attached to the towing vehicle and that the safety chains are secured to the hitch or bumper of the vehicle with enough slack to allow turning. Always use a Class I, 2" ball with this log splitter.

**NEVER** carry any cargo or wood on your log splitter.

**NEVER** allow anyone to sit or ride on your log splitter.

**ALWAYS** disconnect your log splitter from the towing vehicle before operating it.

**ALWAYS** be careful when backing up with your log splitter in tow. It could jackknife.

**ALWAYS** allow for added length of your log splitter when turning, parking, crossing intersections and in all driving situations.

**NEVER** exceed 45 mph when towing your log splitter. Towing the log splitter at speeds higher than 45 mph could result in loss of control, damage to the equipment, serious injury or death. Adjust towing speed for terrain and conditions. Be extra cautious when towing over rough terrain especially railroad crossings.

## ASSEMBLY INSTRUCTIONS

**NOTE:** This log splitter was partially assembled at the factory. Refer to the drawings and parts list should it become necessary to disassemble the unit for repair or replacement of parts

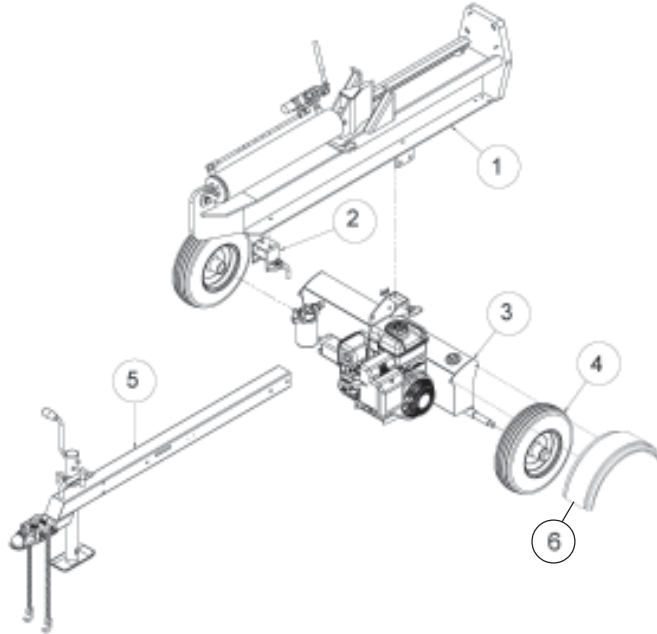

ITEM NO.	PART NO.	DESCRIPTION	QTY.
1	401610S0	Beam Assembly	1
2	40127500	Beam Lock Assembly	1
3	40162100	Tank Assembly	1
4	40035300	Tire and Wheel Assembly	2
5	40127200	Tongue Assembly	1
6	40142200	Fender	2
	40116800	Hardware Kit	1

**NOTE:** This log splitter was partially assembled at the factory. Refer to the drawing and parts list should it become necessary to disassemble the unit for repair or replacement of parts.

**STEP 1:** Remove all the components from the shipping container. Inspect each piece for shipping damage. If any part is damaged, contact your dealer or delivering carrier.

**STEP 2:** Attach the two wheels (1) to the tank assembly wheel spindles using the 3/4" light flat washers (2), 3/4" NF slotted nuts (3), 1/8" x 1-1/2" cotter pins (4) and the hub caps (5). These items are in the hardware package. Tighten the slotted nuts and make sure the wheels rotate freely.

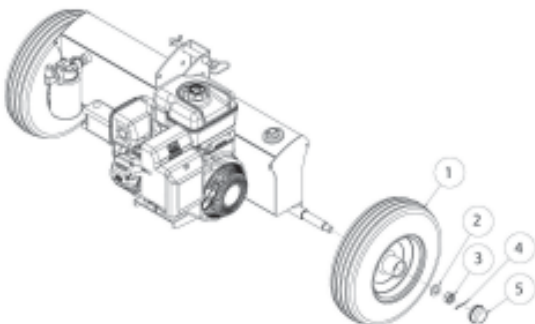

ITEM NO.	PART NO.	DESCRIPTION	QTY.
1	400312B0	Tire and Wheel	2
2	O/L	3/4" Light Flat Washer	2
3	17012000	3/4" Slotted Nut	2
4	O/L	1/8" x 1-1/2" Cotter Pin	2
5	40033200	Hub Cap	2

O/L - Obtain locally. Common fasteners available through hardware and farm stores.

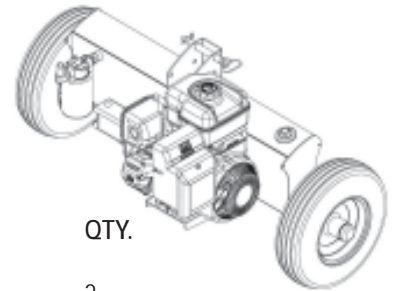

**STEP 3:** Attach the tongue assembly (5) to the tank assembly (1) using two 1/2" NC x 4-1/2" hex cap bolts (2), two 1/2" lock washers (3) and two 1/2" hex nuts (4). Tighten.

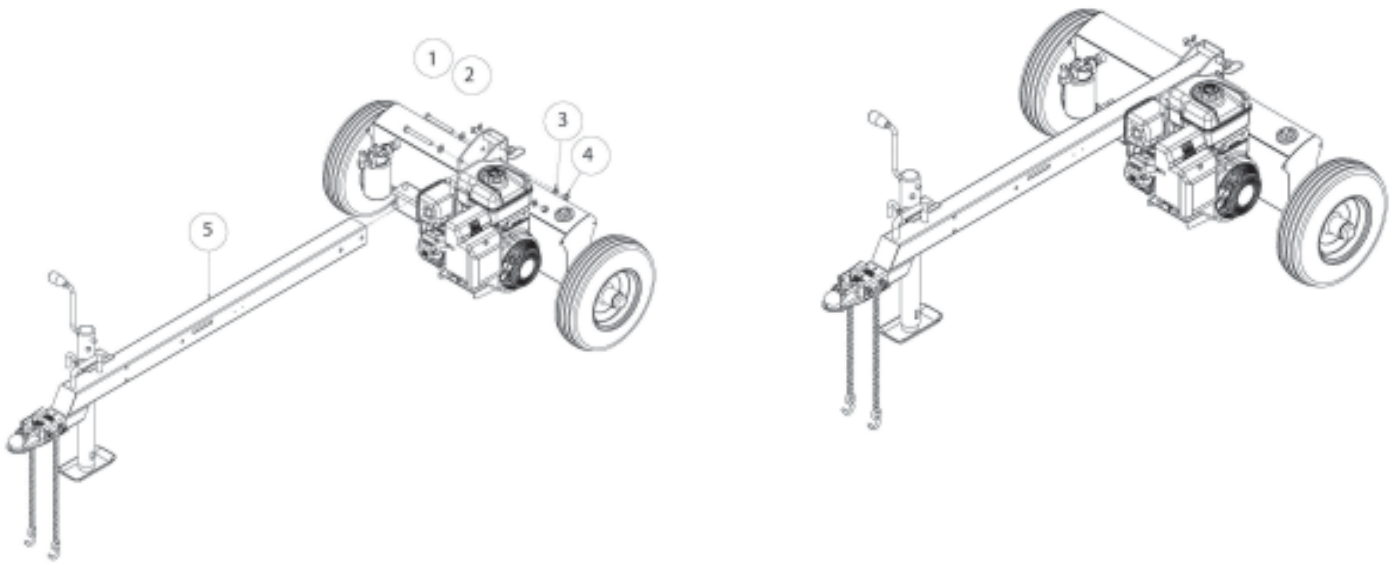

ITEM NO.	PART NO.	DESCRIPTION	QTY.
1	40162100	TankAssembly	1
2	O/L	1/2" NC x 4-1/2 Hex Bolt	2
3	O/L	1/2" Lock Washer	2
4	O/L	1/2" NC Hex Nut	2
5	40127200	Tongue Assembly	1

O/L- Obtain locally. Common fasteners available through hardware and farm stores.

**STEP 4:** Stand the beam (1) up on end. Two people may be needed for this step to ensure safety. Make sure that the beam is stable and on a level surface. Remove the pivot pin (3) and clip pin (2) from the tank assembly. Roll the tongue/ tank assembly into position between the two tabs on the beam (1). Slide the pivot pin (3) through the aligned holes and lock in place with the clip pin (2).

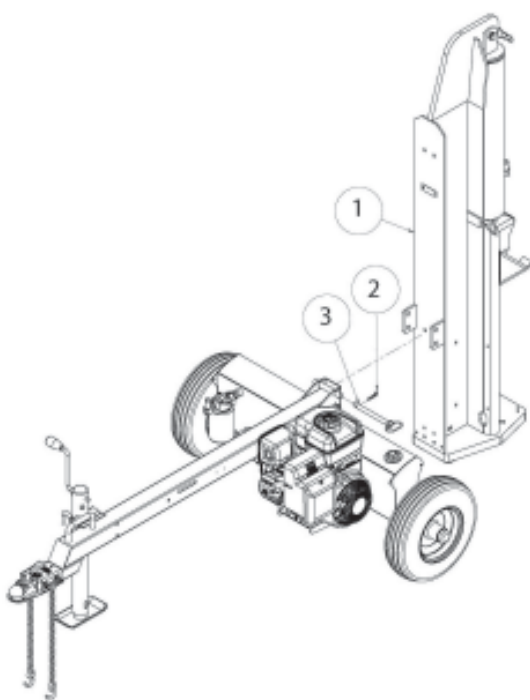

ITEM NO.	PART NO.	DESCRIPTION	QTY.
1	401610S0	Beam Assembly	1
2	O/L	1/2"-3/4" R Clip Pin	1
3	071022WC	Pivot Pin	1

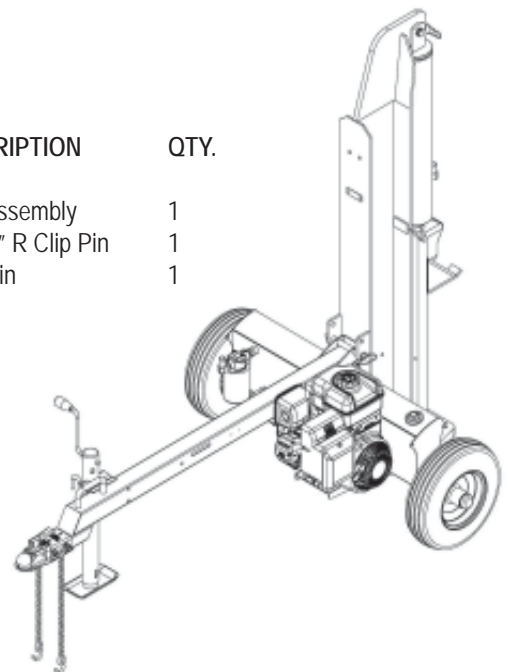

**STEP 5:** Connect the end of the 1/2" ID x 38" hydraulic pressure hose (1) coming from the fitting on the pump to the fitting on the valve . See illustrations below.

**STEP 6:** Slide one hose clamp (3) on the end of the 3/4" x 56" hydraulic return hose (2) that comes from the fitting on the filter . Then connect the hose to the fitting on the valve . See illustrations below.

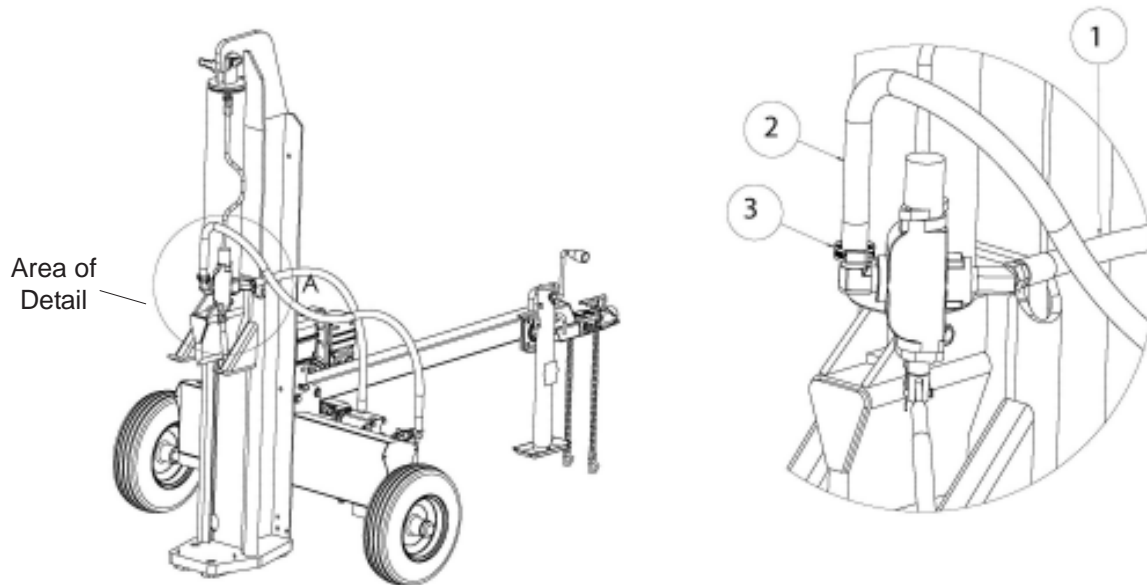

ITEM NO.	PART NO.	DESCRIPTION	QTY.
1	39027500	1/2" X 38" Pressure Hose	1
2	39027400	3/4" x 56" Return Hose	1
3	39031600	Worm Gear Clamp	3

**STEP 7:** Loosely attach the latch assembly (1) to the bottom side of the beam as shown in the diagram using the two 1/2" x 1-1/4" GR 5 hex cap bolts (4), the two 1/2" lock washers (3) and the two 1/2" hex nuts (2). Lower the beam onto the tongue. Center the latch assembly on the tongue and tighten hardware.

ITEM NO.	PART NO.	DESCRIPTION	QTY.
1	40127500	Beam Lock	1
2	O/L	1/2" Hex Nut	2
3	O/L	1/2" Lock Washer	2
4	O/L	1/2" x 1-1/4" GR5 Hex Cap Bolt	2

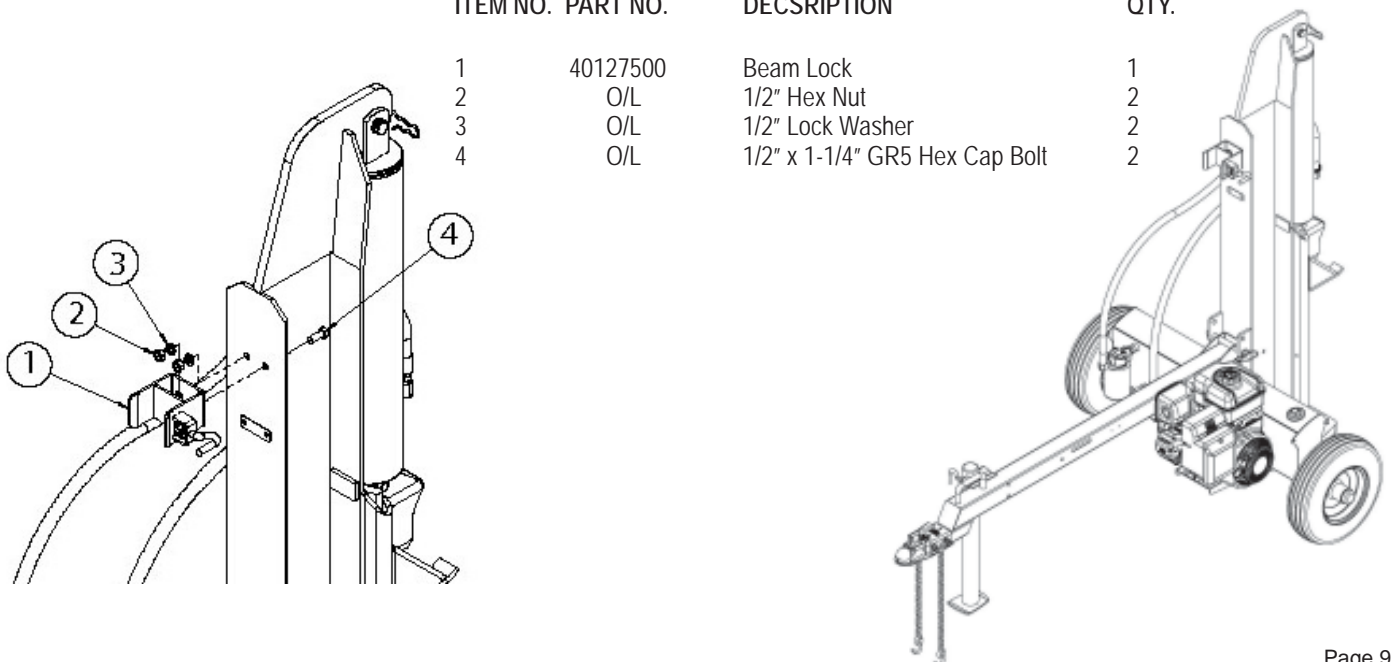

**STEP 8:** Attach the two fenders (1) to the tank/axle using the four 1/4" NC x 3/4" hex cap bolts (2), the four 1/4" flat washers (3), the four 1/4" lock washers (4) and the four 1/4" NC hex nuts (5). Tighten

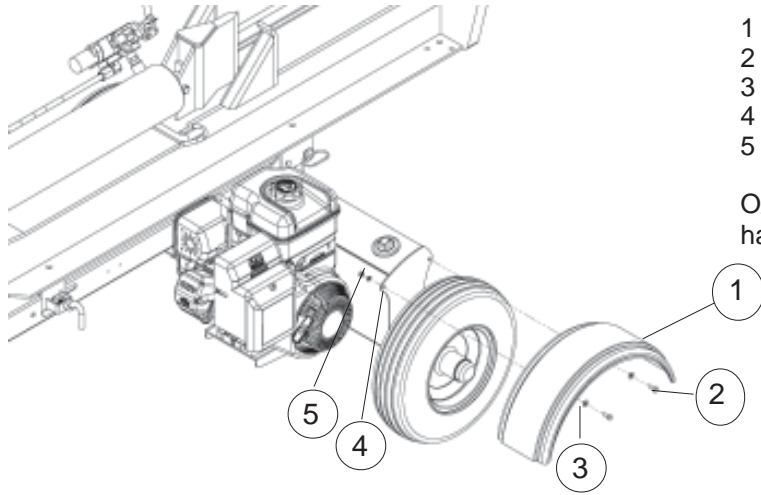

ITEM NO.	PART NO.	DESCRIPTION	QTY.
1	40142200	Fender	2
2	O/L	1/4" NC Hex Bolt	4
3	O/L	1/4" Flat Washer	4
4	O/L	1/4" Lock Washer	4
5	O/L	1/4" NC Hex Nut	4

O/L-Obtain locally. Common fasteners available through hardware and farm stores.

### TANK/ENGINE ASSEMBLY BREAKDOWN

ITEM NO. PART NO. DESCRIPTION  
QTY.

1	O/L	5/16"-18 UNC Nylock Nut	4
2	O/L	5/16" Flat Washer	8
3	O/L	5/16" x 1-1/2" GR5 Hex Bolt	4
4	39027400	3/4" Return Line Hose	1
5	39027500	1/2" x 38" Hydraulic Pressure Hose	1
6	39032000	3/4" NPT x 3/4" Tube	1
7	39034900	3/4" Hex Nipple	1
8	39038100	Straight Fitting, 3/4"NPT to 1/2" Tube	1
9	39038900	1" ID Suction Hose	1
10	390604B0	Filter Base	1
10A	390601A	Filter Element	1
11	39053100	Honda 240 Engine	1
12	39031600	Worm Gear Clamp	3
13	40118800	Tank	1
14	071022WC	Pivot Pin	1
15	O/L	1/2"-3/4" Hairpin Cotter	1
16	39037500	Dip Stick/Breather Cap	1
17	390601A0	Filter Element	1

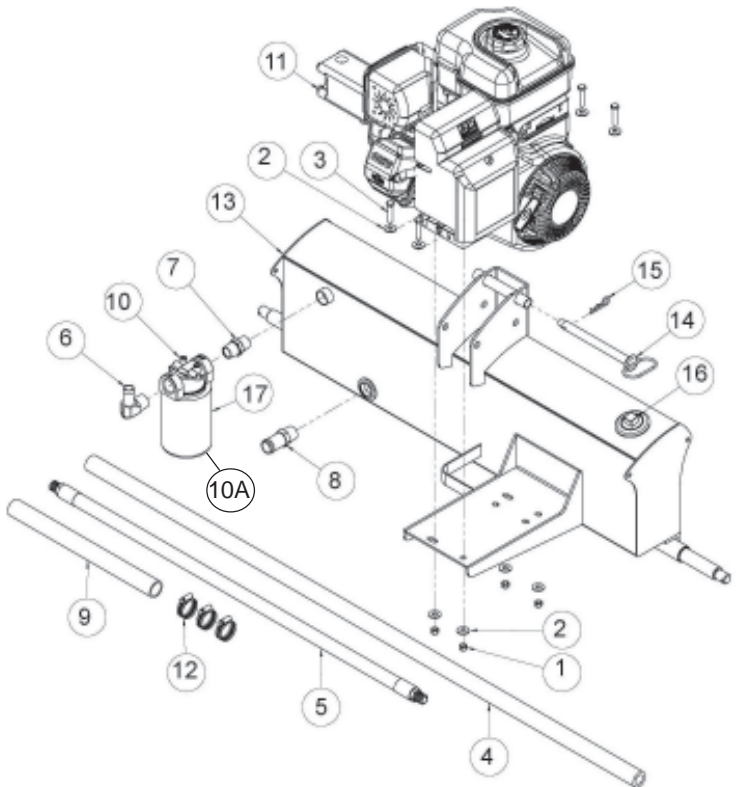

O/L- Obtain locally. Common fasteners available through hardware and farm stores.

10A

## ENGINE/PUMP ASSEMBLY BREAKDOWN

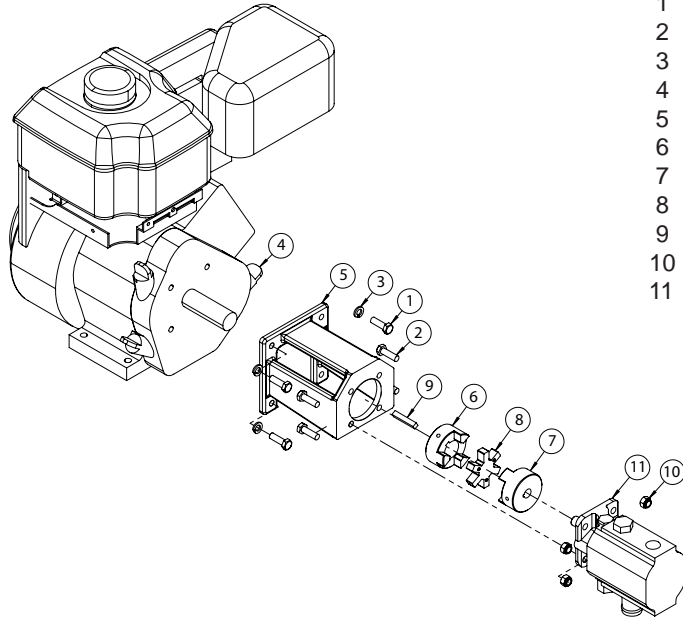

ITEM NO.	PART NO.	DESCRIPTION	QTY.
1	17054400	5/16" X 1" UNF GR5 Bolt	4
2	17053900	5/16" x 1-1/4" GR5 Bolt	4
3	17030900	5/16" Regular Lock Washer	4
4	39053100	Honda 240 Engine	1
5	40081800	Pump Mount	1
6	400825L0	Jaw Coupler, 1" Bore	1
7	400826L0	Jaw Coupler, 1/2" Bore	1
8	400827L0	Rubber Spider	1
9	40034300	1/2" SQ. x 1-1/2" SQ. Key	1
10	39070900	Pump, 16 GPM	1
11	17020700	5/16"-18 UNC, Nylock Nut	4

## BEAM ASSEMBLY BREAKDOWN

ITEM NO.	PART NO.	DESCRIPTION	QTY.
1	O/L	1/2" x 3-1/4" GR 5 Bolt	1
2	O/L	1/2" Regular Lock Washer	1
3	O/L	1/2" Hex Nut	1
4	401413S0	Beam	1
5	40141800	Wedge	1
6	390117B0	5" Cylinder	1
7	07073100	Cylinder Pin	1
8	390406SC	Valve	1
9	39034300	1/2" NPT Nipple	1
10	39032000	3/4" x 3/4" NPT Tube	1
11	39039000	45° Swivel Fitting, 3/4" male, 1/2" female	1
12	39034700	1/2" Pipe to Steel Tubing	2
13	39034600	1/2" Steel Tubing	1

O/L- Obtain locally. Common fasteners available through hardware and farm stores.

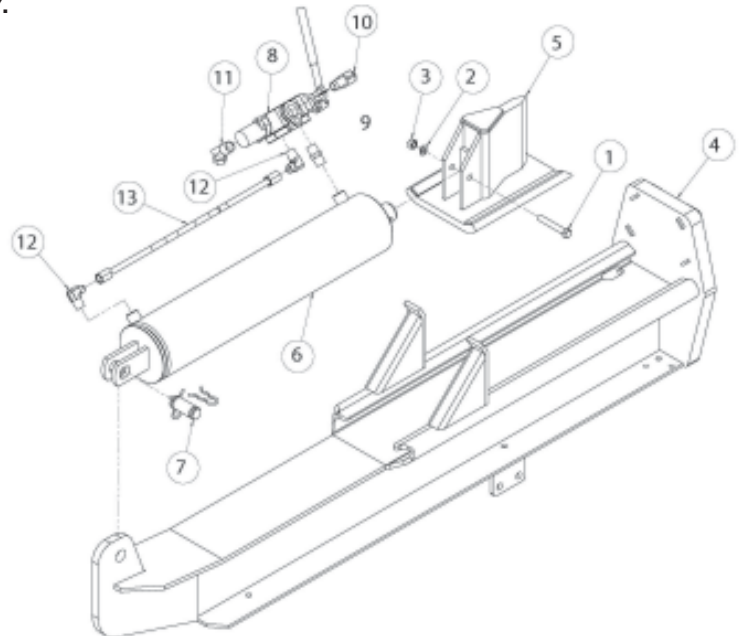

## TONGUE ASSEMBLY BREAKDOWN

ITEM NO.	PART NO.	DESCRIPTION	QTY.
1	17280300	M10 x 1.5 Nylock Nut	2
2	17271600	M10 x 1.5 x 100mm GR5 Bolt	1
3	17272000	M10 x 1.5 x 120mm GR5 Bolt	1
4	17290800	M10 Flat Washer	6
5	40127200	Tongue with Jack	1
6	40034600	Hitch Ball Assembly	1
7	40032300	Safety Chain	2

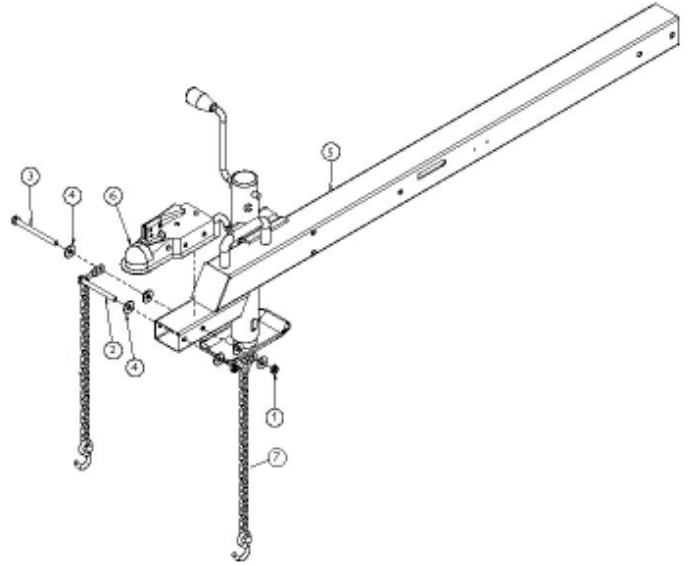

## OPERATING INSTRUCTIONS



***WARNING: Read and thoroughly understand all instructions and safety information before operating this log splitter. Failure to do so may cause serious injury or death. Do not allow anyone to operate this log splitter who has not read this manual. As with all power equipment, a log splitter can be dangerous if assembled or used improperly. Do not operate this log splitter if you have doubts or questions concerning safe operation. Call our customer service department at 1-800-525-8322 to address these concerns.***

***Si no entiende ingles, se prefiere que busque alguien que interprete las instrucciones para usted.***



***CAUTION: DO NOT START OR RUN THE ENGINE BEFORE ADDING OIL IN THE HYDRAULIC RESERVOIR AND OIL IN THE ENGINE.***

**STEP 1:** The hydraulic reservoir must be filled with the oil provided. AW46 hydraulic oil is recommended when oil is needed. Automatic transmission fluid can be substituted and should be used instead of hydraulic oil when temperatures are below 32 degrees F. Use only clean oil and take care to prevent dirt from entering the hydraulic reservoir. Fill the hydraulic tank with approximately 3.5 to 4 gallons of hydraulic oil.



***CAUTION: WHEN TIGHTENING THE BREATHER CAP ON THE TANK, POINT THE HOLE AWAY FROM THE ENGINE AND THE OPERATOR ZONE.***

## ENGINE OIL RECOMMENDATIONS

For temperatures above 40 degrees F use an SAE 30W oil. Using multigrade oil may increase oil consumption. Using SAE 30W oil below 40 degrees F will result in hard starting and possible engine bore damage. For temperatures below 40 degrees F use an SAE 10W-30 or SAE 5W-30 oil. Oil capacity is about 1.16 quart (1.1 liter).

**STEP 2:** After the hydraulic reservoir and the engine crankcase are filled with oil, start the engine. The hydraulic pump should prime itself. With the engine running, move the hydraulic valve lever toward the foot plate. This will cause the cylinder to extend and expel air. When the cylinder is fully extended, retract it. Repeat this procedure several times. An erratic movement of the cylinder indicates that there is still air in the system. Add about 1.0 to 1.5 gallons more. Five gallons will register just above the top fill line on the dip stick. The total capacity of the entire hydraulic system is 6.5 gallons. **NOTE:** If the tank is overfilled it will tend to expel oil from the breather cap when the cylinder is retracted. Cycle the cylinder again until it has a constant speed indicating that all air has been expelled.

## STARTING INSTRUCTIONS

### **Honda 240 Engine**

*Refer also to the Honda Engine Operating and Maintenance Instructions manual for your log splitter.*

- 1) Move the fuel valve lever to the ON position.
- 2) To start a cold engine move the choke lever to the CLOSED position. To restart a warm engine leave the choke lever in the OPEN position.
- 3) Move the throttle lever away from the MIN position, about 1/3 of the way toward the MAX position.
- 4) Turn the engine switch to the ON position.
- 5) Operate the starter (recoil starter). Pull the starter grip lightly until you feel resistance, then pull briskly. Return the starter grip gently. Do not allow the starter grip to snap back against the engine. Return it gently to prevent damage to the starter.

### STOPPING THE ENGINE

To stop the engine in an emergency, simply turn the engine switch to the OFF position. Under normal conditions, use the following procedure.

- 1) Move the throttle lever to the MIN position.
- 2) Turn the engine switch to the OFF position.
- 3) Turn the fuel valve lever to the OFF position.



**CAUTION:** *TURN FUEL SHUT OFF VALVE TO THE "OFF" POSITION PRIOR TO TOWING. FAILURE TO DO SO MAY RESULT IN FLOODING THE ENGINE.*

**NOTE:** The engine maximum governed speed is preset at the factory at 3600 RPM no load speed. When splitting wood the throttle should be set at the maximum speed to develop the horsepower required for the pump.

## **OPERATION**



**WARNING:** *See safety information related to operation of the log splitter on page 3 and 4 of this manual. Make sure that you have the recommended personal protective equipment described on page 1.*

- 1) Set up the log splitter in a clear, level area and block the wheels. Make sure that the suction port on the tank is always on the lower side of the log splitter.
- 2) For horizontal operation place a log on the beam against the foot plate. Make sure the the log is securely on the foot plate and up against the beam. To split wood in the vertical position, release the pin on the beam latch located near the front end of the beam. Carefully tilt the beam up until the foot plate is sitting squarely on the ground and the log splitter is stable. Place the log on the foot plate up against the beam. When the beam is returned to the horizontal position make sure the beam latch is securely locked down. See illustrations in Step 8 on page 10.
- 3) With the engine running, depress the valve handle so that the cylinder will drive the wedge into the log. Extend the cylinder until the log splits or to the end of its stroke. If the log has not completely split after the cylinder has reached the end of its extension, retract the cylinder.  
**IMPORTANT:** Leaving the valve in the "actuate" position at the end of the stroke may damage the pump. Always use extra care when splitting logs with unsquare ends.

**NOTE:** For operation in wooded areas, obtain a spark arrestor for the exhaust system. See the engine operating and maintenance manual and check with your authorized Honda service center. See also Fire Prevention on page 5 of this manual.

**IMPORTANT:** *TO EXTEND THE LIFE OF THE HYDRAULIC CYLINDER, AVOID "BOTTOMING OUT" WEDGE PLATE TO THE FOOT PIECE. TO CONFORM WITH INDUSTRY SAFETY RECOMMENDATIONS, THE WEDGE STOPS 1.5 INCHES FROM THE END OF THE STROKE.*

## **TOWING**

This log splitter is equipped with pneumatic tires, a Class I coupler (2 in. diameter ball required) and safety chains. Before towing, the safety chains must be secured to the hitch or bumper of the vehicle. Local regulations should be checked regarding licensing, lights, towing, etc. Turn fuel shut off valve on the engine to the "Off" position prior to towing. Failure to do so may result in flooding the engine. Do not exceed 45 mph when towing this log splitter. See also Towing Safety on page 6 of this manual.

## **MAINTENANCE**

- 1) Consult the operating and maintenance instructions of the engine manufacturer for engine care and maintenance.
- 2) Always check the oil level of the hydraulic reservoir before operation. Operating the log splitter without an adequate oil supply will cause severe damage to the pump.
- 3) Change the oil filter after the first 25 hours of operation. There after change the oil filter every 100 hours or seasonally, whichever comes first.
- 4) To drain the hydraulic oil, loosen the clamp on the hose coming from the fitting on the bottom of the tank. It is located just to the right of the oil filter.
- 5) If the wedge becomes dull or nicked, it can be removed and sharpened. Remove the 1/2 in. diameter bolt that connects the wedge to the cylinder. hose from the valve. The hose from the valve may need to be removed. Carefully lift the cylinder to allow the wedge to slide forward. The wedge can now be lifted off and sharpened.
- 6) Clean the breather cap after 25 hours of operation. Clean it more often when operated in dusty conditions. To clean, remove the breather cap from the tank and flush with kerosene or liquid detergent to remove the dirt.
- 7) See also Repair and Maintenance Safety on page 4 of this manual.
- 8) All replacement parts must meet manufacturer's specifications.

**IMPORTANT NOTICE**

We, the manufacturer, reserve the right to change the product and/or specifications in this manual without notification. The manual is for information usage only and the pictures and drawings depicted herein are for reference only.

**== NOTES ==**

---

**Warranty Repair and Service**

*Do not return this product to the store for warranty issues or repair. Call 1-800-525-8322 for the location of the nearest service center.*

Record the information below for future reference.

Model No. \_\_\_\_\_

Serial No. \_\_\_\_\_

Date of Purchase \_\_\_\_\_

Place of Purchase \_\_\_\_\_

\_\_\_\_\_  
\_\_\_\_\_  
\_\_\_\_\_

# SPECIFICATIONS

Engine	Honda 240cc Engine
Pump	Two-Stage, 16 gpm
Cylinder	5 in. Diameter x 24 in. Stroke
Valve	Auto-Return
Maximum Splitting Force	35 Tons
Maximum Log Length	26 in.
Cycle Time*	14 Seconds
Wheels	4.80 x 8 in.
Wedge	7 in. High with Spreader Wings
Beam Size	8 in. x 10 in. with Built-In Log Cradle
Hydraulic Capacity	6.5 Gallons Maximum
Filter	Spin-On Replaceable Filter
Height	72 in. in Vertical Position 42 in. in Horizontal Position
Length	78 in.
Width	49 in.
Shipping Weight	675 lbs.
*Ideal case cycle time. Actual cycle time will vary depending on temperature, altitude, engine speed, pump efficiency, etc.	



A brand of Special Products Co.  
 15000 W. 44th Ave. Golden Colorado 80403  
 303-279-5544 Toll Free USA 800-525-8322 Fax 303-278-3432  
 Email: speeco@speeco.com Web: www.speeco.com